

## Layflat and Gusseted

# CUSTOM CAPABILITIES

With over 58 extrusion lines in 5 manufacturing facilities, we can produce a wide range of custom LDPE and LLDPE bags, sheeting and tubing. Choose from 16 standard colors, 3 venting styles and a host of performance additives.

### MADE IN THE U.S.A.

Medium and larger sized items are engineered with optimized clarity and strength to provide over three times the impact and twice the tensile strength of traditional LDPE. These products are exclusively made in the U.S.A. by an ISO 9001 manufacturer.

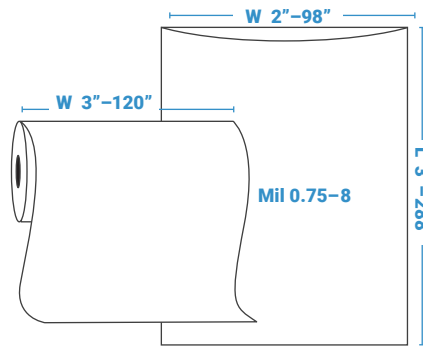

### CUSTOM VENTING

Vented Bags W: 4"–98" W+D max. = 150"  
 Micro-Perforation W: 10"–60" W+D max. = 118"

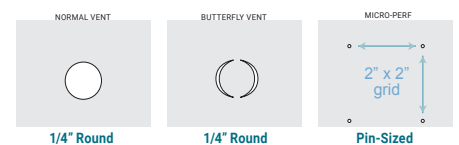
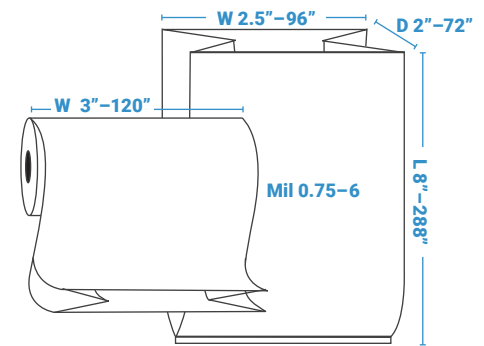

### PRINTED BAGS

You can design, quote and order printed items with your own custom images. Quotes are generated quickly and include precise technical line drawings that include your image and text sized to scale, ready for sharing as a PDF attachment.

### MATERIALS & ADDITIVES

- Anti-Block** For easy opening and loading
- Anti-Static** For static-dissipative film
- HDPE** High-Density Polyethylene for thinner, more economical film
- High Slip** For reduced friction between film
- LDPE** Low-Density Polyethylene for standard strength film
- LLD** High Strength Linear Low-Density
- LLDPE** Linear Low-Density Polyethylene for high strength film
- Metallocene** For high strength film or cold storage
- Non-Slip** To increase friction between film
- Non-Scratch** No anti-block for a smoother film surface
- Postal-Approved** Higher slip & anti-static for film used in USPS mailings
- UVI/UVB** Ultraviolet Inhibitor/Absorber to protect film and contents from the sun
- VCI** Vapor Corrosion Inhibitor to prevent rust

### PACKAGING DETAILS

- Cases or Rolls** Loose in a case or on a roll for easy dispensing
- Case or Roll Count** Get the quantity that works best for your customer
- Boxed Rolls** Protect product prior to use
- Cradle Packed Rolls** Use less packaging, save money and provide more stable shipments
- Tray-Packed Rolls** Use less packaging, saves time unpacking

### FILM COLORS (SWATCHES ARE APPROXIMATE)

	Black		Blue-Green
	Brown		Leaf Green
	Buff		Dark Green
	Gray		Red
	White		Orange
	Med. Blue		Yellow
	Sky Blue		Pink
	Baby Blue		Purple

**Tint** For film that you can see through in interior light  
**Color** For film you may not see through in interior light  
**Opaque** For film you cannot see through in interior light (black film only, minimum thickness 2.5 mil)

CONTACT US FOR  
 MORE INFORMATION



Veteran Packaging Company  
 900 Rutter Avenue  
 Forty Fort, Pennsylvania 18704

www.vetpackagingco.com  
 bsmith@vetpackagingco.com  
**410-830-9496**